



DECLARATION OF PERFORMANCE

No: DoP-170079 [EN]



Unique identification code of the product-type:

Sandwich Panel Screw ESSVE-ST (self-drilling for steel)
Sandwich Panel Screw ESSVE-WD (self-tapping for wood)

Intended use:

The screws ESSVE-ST / ESSVE-WD are intended to be used for fastening sandwich panels to steel or timber substructures. The sandwich panel can either be used as wall or roof cladding or as load bearing wall and roof element.

Fastening screws for sandwich panels are intended to be used in internal environments with corrosion class C1 in accordance with EN ISO 12944-2.

European Assessment Document:

EAD 330047-01-0602

European Technical Assessment:

ETA-17/0079 (issued on 2020-03-27)

System of AVCP:

2+

Manufacturer:

ESSVE Produkter AB
BOX 7091
164 07 Kista
Sweden

info@essve.se

Technical Assessment Body:

INSTYTUT TECHNIKI BUDOWLANEJ (ITB)

Notified Body:

1488



DECLARATION OF PERFORMANCE

No: DoP-170079 [EN]

ESSVE
GET IT DONE

Declared performance:

In the ETA the component to be fastened is component I and the supporting structure is component II. Component I is always a sandwich panel (of varying thickness), component II has declared values for either steel or timber, as indicated by the Annex.

ID code	Article Number	Material/Coating	Max. drill capacity [mm]	Essential characteristics	Performance	Harmonised technical specification
ESSVE-ST	10563170, 10563172, 10563174, 10563176, 10563178, 10563180, 10563182, 10563184, 10563188, 10563189	EZP	6,0	$N_{R,k}$ [kN] $V_{R,k}$ [kN] u [mm]	Annex 2 (steel supporting structure)	ETA-17/0079
ESSVE-ST	10563156, 10563158, 10563160, 10563163, 10563164, 10563166, 10563167, 10563168, 10563169, 10563190, 10563192	EZP	12,0	$N_{R,k}$ [kN] $V_{R,k}$ [kN] u [mm]	Annex 4 (steel supporting structure)	ETA-17/0079
ESSVE-ST	10567070, 10567090, 10567110, 10567125, 10567135, 10567150, 10567175, 10567186, 10567200, 10567230, 10567250, 10567285, 10567300	CorrSeal	12,0	$N_{R,k}$ [kN] $V_{R,k}$ [kN] u [mm]	Annex 5 (steel supporting structure)	ETA-17/0079
ESSVE-WD	10565100, 10565102, 10565104, 10565106, 10565108, 10565110, 10565112, 10565114	RUSPERT	1,0	$N_{R,k}$ [kN] $V_{R,k}$ [kN] u [mm]	Annex 6 (timber supporting structure)	ETA-17/0079

The performance of the product identified above is in conformity with the set of declared performance/s. This declaration of performance is issued, in accordance with Regulation (EU) No 305/2011, under the sole responsibility of the manufacturer above.

Signed for and on behalf of the manufacturer by:

Viktor Bukowski
Product Developer/Technical expert – Fasteners

Kista 2021-10-07



INSTYTUT TECHNIKI BUDOWLANEJ
PL 00-611 WARSZAWA
ul. Filtrowa 1
tel.: (+48 22) 825-04-71
(+48 22) 825-76-55
fax: (+48 22) 825-52-86
www.itb.pl



Member of



www.eota.eu

European Technical Assessment

**ETA-17/0079
of 27/03/2020**

General Part

Technical Assessment Body issuing the European Technical Assessment

Instytut Techniki Budowlanej

Trade name of the construction product

SANDWICHPANEL SCREW ESSVE-ST and
SANDWICHPANEL SCREW ESSVE-WD

Product family to which the construction product belongs

Fastening screws for sandwich panels

Manufacturer

ESSVE PRODUKTER AB
Esbogatan 14
SE-16474 Kista
Sweden

Manufacturing plants

Essve plants

This European Technical Assessment contains

11 pages including 7 Annexes which form an integral part of this Assessment

This European Technical Assessment is issued in accordance with regulation (EU) No 305/2011, on the basis of

European Assessment Document EAD 330047-01-0602 "Fastening screws for sandwich panels"

This version replaces

ETA-17/0079 issued on 30/03/2017

This European Technical Assessment is issued by the Technical Assessment Body in its official language. Translations of this European Technical Assessment in other languages shall fully correspond to the original issued document and shall be identified as such.

Communication of this European Technical Assessment, including transmission by electronic means, shall be in full. However, partial reproduction may only be made with the written consent of the issuing Technical Assessment Body. Any partial reproduction has to be identified as such.

Specific Part

1 Technical description of the product

The fastening screws for sandwich panels SANDWICHPANEL SCREW ESSVE-ST and SANDWICHPANEL SCREW ESSVE-WD are a self-drilling and self-tapping screws listed in Table 1. Screws are supplied with a steel washers and an EPDM sealing rings. For details see the Annexes 2 to 6.

The fastening screw for sandwich panels and the corresponding connections are subject to tension and shear forces.

Table 1

No.	Screw	Material	Annex
1	SANDWICHPANEL SCREW ESSVE-ST-EZP 5,5/6,3xL	galvanized carbon steel with $\geq 10 \mu\text{m}$ of zinc	2
2	SANDWICHPANEL SCREW ESSVE-ST-Corrseal 5,5/6,3xL/6	galvanized carbon steel with ceramic coating	3
3	SANDWICHPANEL SCREW ESSVE-ST-EZP 5,5/6,3xL/12	galvanized carbon steel with $\geq 10 \mu\text{m}$ of zinc	4
4	SANDWICHPANEL SCREW ESSVE-ST-Corrseal 5,5/6,3xL/12	galvanized carbon steel with ceramic coating	5
5	SANDWICHPANEL SCREW ESSVE-WD-Corrseal 6,3/7,0xL	galvanized carbon steel with ceramic coating	6

2 Specification of the intended use in accordance with the applicable European Assessment Document (EAD)

The fastening screws for sandwich panels are intended to be used for fastening sandwich panels to steel or timber substructures. For details see the Annexes 2 to 6. The component to be fastened is component I and the supporting structure is component II. The sandwich panel can either be used as wall or roof cladding or as load bearing wall and roof element.

Fastening screws for sandwich panels are intended to be used in internal environments with corrosion category class C1 in accordance with EN ISO 12944-2.

Furthermore the intended use comprises connections with predominantly static loads (e.g. wind loads, dead loads).

Example of execution of a connections are given in Annex 1.

The provisions made in this European Technical Assessment are based on an assumed working life of the fasteners of 25 years. The indications given on the working life cannot be interpreted as a guarantee given by the producer or Technical Assessment Body, but are to be regarded only as a means for choosing the right products in relation to the expected economically reasonable working life of the works.

3 Performance of the product and references to the methods used for its assessment

3.1 Performance of the product

3.1.1 Mechanical resistance and stability (BWR 1)

The characteristic values of the shear resistance of connections and tension resistance of connections with the fasteners as well as the maximum head displacement are given in Annex 2 to 6. The values were determined by tests according to EAD 330047-01-0602.

The design values shall be determined according to Annex 7 and EAD 330047-01-0602.

For the corrosion protection the rules given in EN 1993-1-3 and EN 1993-1-4 shall be taken into account.

3.1.2 Safety in case of fire (BWR 2)

The fastening screws are considered to satisfy the requirements of performance class A1 of reaction to fire, in accordance with the provisions of the EC Decision 96/603/EC (as amended) without the need for testing on the basis of its listing in that decision.

3.2 Methods used for the assessment

The assessment of the products has been made in accordance with EAD 330047-01-0602.

4 Assessment and verification of constancy of performance (AVCP) system applied, with reference to its legal base

According to Decision 1998/214/EC, amended by 2001/596/EC, of the European Commission the system 2+ of assessment and verification of constancy of performance applies (see Annex V to Regulation (EU) No 305/2011).

5 Technical details necessary for the implementation of the AVCP system, as provided in the applicable European Assessment Document (EAD)

Technical details necessary for the implementation of the AVCP system are laid down in the control plan deposited in Instytut Techniki Budowlanej.

For type testing the results of the tests performed as part of the assessment for the European Technical Assessment shall be used unless there are changes in the production line or plant. In such cases the necessary type testing has to be agreed between Instytut Techniki Budowlanej and the notified body.

Issued in Warsaw on 27/03/2020 by Instytut Techniki Budowlanej



Anna Panek, MSc
Deputy Director of ITB

Examples of execution of a connections

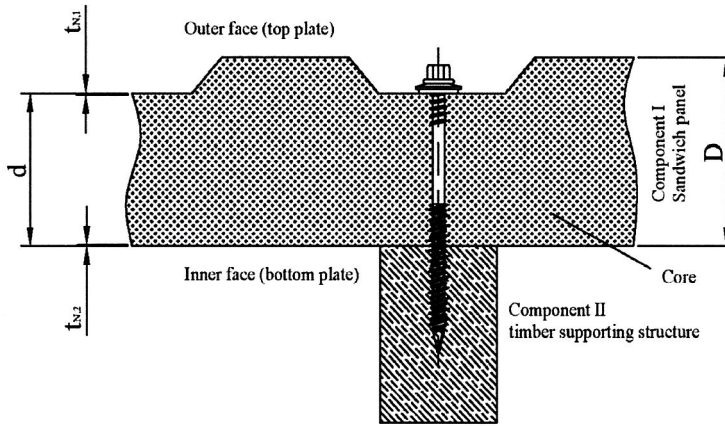
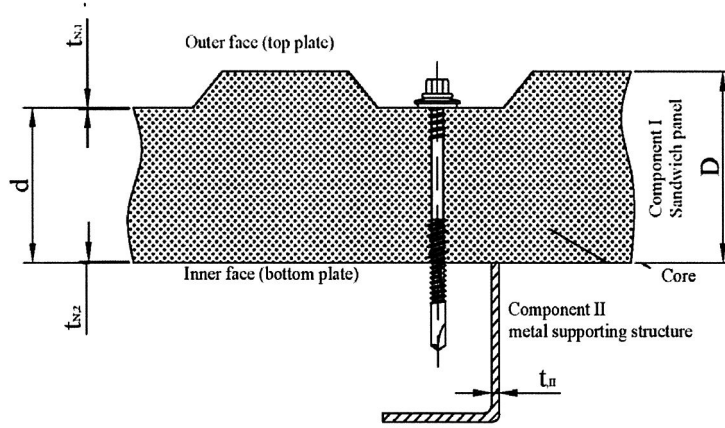

Type of loading

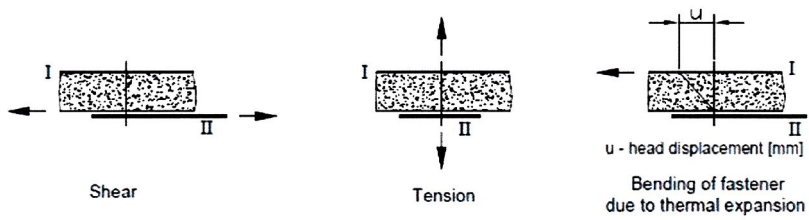

SANDWICHPANEL SCREW ESSVE-ST and SANDWICHPANEL SCREW ESSVE-WD Fastening screws for sandwich panels

Example of execution of a connections. Type of loading.

Annex 1
of European
Technical Assessment
ETA-17/0079

<p>Materials Fastener: carbon steel – SAE1022 quenched, tempered and galvanized</p> <p>Washer: EPDM sealing ring with metal top made of carbon steel, galvanized</p> <p>Component I: S280GD, S320GD or S350GD – EN 10346</p> <p>Component II: $t_{II} \leq 2$ mm: S280GD, S320GD or S350GD – EN 10346 $t_{II} > 2$ mm: S235 – EN 10025-1</p> <p>Drilling capacity: $\Sigma(t_{N2} + t_{II}) \leq 6$ mm</p>	
<p>Timber substructures no performance assessed</p>	<p>$L_W = 65 - 275$ mm $d_{W1} = 6,3$ mm $d_{W2} = 5,5$ mm $k = 5,5$ mm $S = 8,0$ mm $D = 19,0$ mm</p>

		Component II: t_{II} [mm]	2,00	2,50	3,00	4,00	5,00
Component I: t_{N1} or t_{N2} [mm]	V _{R,k} [kN]	0,50	1,60	1,60	1,60	1,60	1,60
		0,55	1,60	1,60	1,60	1,60	1,60
		0,63	2,03	2,03	2,03	2,03	2,03
		0,75	2,72	2,72	2,72	2,72	2,72
		0,88	2,72	2,72	2,72	2,72	2,72
		1,00	2,72	2,72	2,72	2,72	2,72
	N _{R,k} [kN]	0,50	2,58	2,58	2,58	2,58	2,58
		0,55	2,58	2,58	2,58	2,58	2,58
		0,63	2,58	2,58	2,58	4,69	4,69
		0,75	2,58	2,58	2,58	5,38	5,38
		0,88	2,58	2,58	2,58	5,38	5,38
		1,00	2,58	2,58	2,58	5,38	5,38
Max. head displacement u depending on the sandwich panel thickness [mm]	30	12	12	12	1,5	1,5	
	40	12	12	12	1,5	1,5	
	50	12	12	12	1,5	1,5	
	60	18	18	18	4	4	
	70	18	18	18	4	4	
	80	18	18	18	4	4	
	90	23	23	23	10	10	
	100	23	23	23	10	10	
	120	23	23	23	10	10	
	>140	23	23	23	10	10	

<p>SANDWICHPANEL SCREW ESSVE-ST and SANDWICHPANEL SCREW ESSVE-WD Fastening screws for sandwich panels</p>	<p>Annex 2 of European Technical Assessment ETA-17/0079</p>
<p>SANDWICHPANEL SCREW ESSVE-ST-EZP 5,5/6,3xL/6 self-drilling screws with hexagon head and sealing washer Ø19 mm with metal top made of carbon steel galvanized (S)</p>	

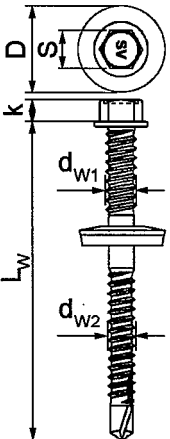
<p>Materials</p> <p>Fastener: carbon steel – SAE1022 quenched, tempered, galvanized and additionally protected by ceramic coating CorrSeal or the equivalent ceramic coating</p> <p>Washer: EPDM sealing ring with metal top made of stainless steel</p> <p>Component I: S280GD, S320GD or S350GD – EN 10346</p> <p>Component II: $t_{II} \leq 2$ mm: S280GD, S320GD or S350GD – EN 10346 $t_{II} > 2$ mm: S235 – EN 10025-1</p> <p>Drilling capacity: $\Sigma(t_{N2} + t_{II}) \leq 6$ mm</p>	 <p>$L_w = 65 - 275$ mm $d_{w1} = 6,3$ mm $d_{w2} = 5,5$ mm $k = 5,5$ mm $S = 8,0$ mm $D = 19,0$ mm</p>
<p>Timber substructures no performance assessed</p>	

		Component II: t_{II} [mm]					
		2,00	2,50	3,00	4,00	5,00	
Component I: t_{N1} or t_{N2} [mm]	$V_{R,k}$ [kN]	0,50	1,60	1,60	1,60	1,60	1,60
		0,55	1,60	1,60	1,60	1,60	1,60
		0,63	2,03	2,03	2,03	2,03	2,03
		0,75	2,72	2,72	2,72	2,72	2,72
		0,88	2,72	2,72	2,72	2,72	2,72
		1,00	2,72	2,72	2,72	2,72	2,72
	$N_{R,k}$ [kN]	0,50	2,58	2,58	2,58	2,58	2,58
		0,55	2,58	2,58	2,58	2,58	2,58
		0,63	2,58	2,58	2,58	4,69	4,69
		0,75	2,58	2,58	2,58	5,38	5,38
0,88		2,58	2,58	2,58	5,38	5,38	
1,00	2,58	2,58	2,58	5,38	5,38		
Max. head displacement u depending on the sandwich panel thickness [mm]	30	12	12	12	1,5	1,5	
	40	12	12	12	1,5	1,5	
	50	12	12	12	1,5	1,5	
	60	18	18	18	4	4	
	70	18	18	18	4	4	
	80	18	18	18	4	4	
	90	23	23	23	10	10	
	100	23	23	23	10	10	
	120	23	23	23	10	10	
>140	23	23	23	10	10		

<p>SANDWICHPANEL SCREW ESSVE-ST and SANDWICHPANEL SCREW ESSVE-WD Fastening screws for sandwich panels</p>	<p>Annex 3 of European Technical Assessment ETA-17/0079</p>
<p>SANDWICHPANEL SCREW ESSVE-ST-CorrSeal 5,5/6,3xL/6 self-drilling screws with hexagon head and sealing washer $\varnothing 19$ mm with metal top made of stainless steel (S)</p>	

<p>Materials Fastener: carbon steel – SAE1022 quenched, tempered and galvanized</p> <p>Washer: EPDM sealing ring with metal top made of carbon steel, galvanized</p> <p>Component I: S280GD, S320GD or S350GD – EN 10346</p> <p>Component II: $t_{II} \leq 2$ mm: S280GD, S320GD or S350GD – EN 10346 $t_{II} > 2$ mm: S235 – EN 10025-1</p> <p>Drilling capacity: $\Sigma(t_{N2} + t_{II}) \leq 12$ mm</p>		<p>$L_w = 65 - 300$mm $d_{w1} = 6,3$ mm $d_{w2} = 5,5$ mm $k = 5,5$ mm $S = 8,0$ mm $D = 19,0$ mm</p>
<p>Timber substructures no performance assessed</p>		

Component II: t_{II} [mm]		4,00	5,00	6,00	8,00	10,00	11,00
Component I: $t_{N,1}$ or $t_{N,2}$ [mm]	V _{R,k} [kN]	0,50	1,73	1,73	1,73	1,73	1,73
		0,55	1,73	1,73	1,73	1,73	1,73
		0,63	2,24	2,24	2,24	2,24	2,24
		0,75	3,10	3,10	3,10	3,10	3,10
		0,88	3,10	3,10	3,10	3,10	3,10
		1,00	3,10	3,10	3,10	3,10	3,10
	N _{R,k} [kN]	0,50	3,75	3,75	3,75	3,75	3,75
		0,55	3,75	3,75	3,75	3,75	3,75
		0,63	4,69	4,69	4,69	4,69	4,69
		0,75	5,38	5,38	5,38	5,38	5,38
Max. head displacement u depending on the sandwich panel thickness [mm]	0,88	5,38	5,38	5,38	5,38	5,38	
	1,00	5,38	5,38	5,38	5,38	5,38	
	30	1,5	1,5	1,5	1,5	1,5	
	40	1,5	1,5	1,5	1,5	1,5	
	50	1,5	1,5	1,5	1,5	1,5	
	60	4	4	4	4	4	
	70	4	4	4	4	4	
	80	4	4	4	4	4	
	90	10	10	10	10	10	
	100	10	10	10	10	10	
120	10	10	10	10	10		
>140	10	10	10	10	10		

<p>SANDWICHPANEL SCREW ESSVE-ST and SANDWICHPANEL SCREW ESSVE-WD Fastening screws for sandwich panels</p>	<p>Annex 4 of European Technical Assessment ETA-17/0079</p>
<p>SANDWICHPANEL SCREW ESSVE-ST-EZP 5,5/6,3xL/12 self-drilling screws with hexagon head and sealing washer Ø19 mm with metal top made of carbon steel galvanized (S)</p>	

Materials Fastener: carbon steel – SAE1022 quenched, tempered, galvanized and additionally protected by ceramic coating CorrSeal or the equivalent ceramic coating Washer: EPDM sealing ring with metal top made of stainless steel Component I: S280GD, S320GD or S350GD – EN 10346 Component II: $t_{fi} \leq 2$ mm: S280GD, S320GD or S350GD – EN 10346 $t_{fi} > 2$ mm: S235 – EN 10025-1		<p> $L_w = 70 - 300$ mm $d_{w1} = 6,3$ mm $d_{w2} = 5,5$ mm $k = 5,5$ mm $S = 8,0$ mm $D = 19,0$ mm </p>
Drilling capacity: $\Sigma(t_{N2} + t_{fi}) \leq 12$ mm		
Timber substructures no performance assessed		

Component II: t_{fi} [mm]		4,00	5,00	6,00	8,00	10,00	11,00
Component I: t_{N1} or t_{N2} [mm]	$V_{R,k}$ [kN]	0,50	1,73	1,73	1,73	1,73	1,73
		0,55	1,73	1,73	1,73	1,73	1,73
		0,63	2,24	2,24	2,24	2,24	2,24
		0,75	3,10	3,10	3,10	3,10	3,10
		0,88	3,10	3,10	3,10	3,10	3,10
	$N_{R,k}$ [kN]	0,50	3,75	3,75	3,75	3,75	3,75
		0,55	3,75	3,75	3,75	3,75	3,75
		0,63	4,69	4,69	4,69	4,69	4,69
		0,75	5,38	5,38	5,38	5,38	5,38
		0,88	5,38	5,38	5,38	5,38	5,38
Max. head displacement u depending on the sandwich panel thickness [mm]	30	1,5	1,5	1,5	1,5	1,5	
	40	1,5	1,5	1,5	1,5	1,5	
	50	1,5	1,5	1,5	1,5	1,5	
	60	4	4	4	4	4	
	70	4	4	4	4	4	
	80	4	4	4	4	4	
	90	10	10	10	10	10	
	100	10	10	10	10	10	
	120	10	10	10	10	10	
>140	10	10	10	10	10		

SANDWICH PANEL SCREW ESSVE-ST and SANDWICH PANEL SCREW ESSVE-WD Fastening screws for sandwich panels	Annex 5 of European Technical Assessment ETA-17/0079
SANDWICH PANEL SCREW ESSVE-ST-CorrSeal 5,5/6,3xL/12 self-drilling screws with hexagon head and sealing washer $\varnothing 19$ mm with metal top made of stainless steel (S)	

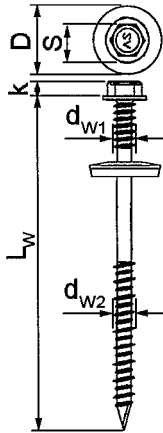
<p>Materials Fastener: carbon steel – SAE1022 quenched, galvanized and additionally protected by ceramic coating CorrSeal or the equivalent ceramic coating</p> <p>Washer: EPDM sealing ring with metal top made of stainless steel</p> <p>Component I: S280GD, S320GD or S350GD – EN 10346</p> <p>Component II: Structural timber – EN 14081</p>	
Drilling capacity: -	
<p>Timber substructures For timber substructures performance assessed with</p> <p>$M_{y,Rk} = 8,910 \text{ Nm}$ $f_{ax,k} = 14,444 \text{ N/mm}^2$ for $l_{ef} \geq 30 \text{ mm}$</p>	<p>$L_w = 100 - 310 \text{ mm}$ $d_{w1} = 7,0 \text{ mm}$ $d_{w2} = 6,3 \text{ mm}$ $k = 5,5 \text{ mm}$ $S = 8,0 \text{ mm}$ $D = 19,0 \text{ mm}$</p>

Component II: wood class \geq C24		Effective length l_{ef} [mm]	
		$\geq 30,00$	
Component I: $t_{N,1}$ or $t_{N,2}$ [mm]	V _{R,k} [kN]	0,50	1,85
		0,55	1,85
		0,63	2,38
		0,75	2,77
		0,88	2,77
		1,00	2,77
	N _{R,k} [kN]	0,50	2,73
		0,55	2,73
		0,63	2,73
		0,75	2,73
		0,88	2,73
		1,00	2,73
Max. head displacement u depending on the sandwich panel thickness [mm]	30	1	
	40	1	
	50	1	
	60	1,5	
	70	1,5	
	80	1,5	
	90	2	
	100	2	
	≥ 140	2	

<p>SANDWICHPANEL SCREW ESSVE-ST and SANDWICHPANEL SCREW ESSVE-WD Fastening screws for sandwich panels</p>	<p>Annex 6 of European Technical Assessment ETA-17/0079</p>
<p>SANDWICHPANEL SCREW ESSVE-WD-CorrSeal 6,3/7,0xL self-tapping screws with hexagon head and sealing washer $\varnothing 19 \text{ mm}$ with metal top made of stainless steel (S)</p>	

Determination of Design Values

1. Determination of Design Shear Resistance

The determination of the design values of the shear resistance depends on the type of substructure.

For Metal Supporting Substructures the following applies:

The design values $V_{R,d}$ of the shear resistance are the characteristic values of the shear resistance divided by the recommended partial safety factor $\gamma_M = 1,33$. The recommended partial safety factor γ_M should be used in cases where no value is given in national regulations of the Member State where the fastening screws are used.

For Timber Supporting Substructures the following applies:

The design values $V_{R,d}$ of the shear resistance are the characteristic values of the shear resistance multiplied by k_{mod} according to EN 1995-1-1 Section 8.7 (Screwed connections), Table 3.1, and divided by the recommended partial safety factor $\gamma_M = 1,33$. If failure of the inner face with the thickness t_{N2} and not failure of the timber substructure is the relevant failure mode then $k_{mod} = 1.0$.

The recommended partial safety factor γ_M should be used in cases where no value is given in national regulations of the Member State where the fastening screws are used.

2. Determination of Design Pull-through, Pull-out and Tension Resistance

The design values of the pull-through resistance are the characteristic values of the pull-through resistance divided by the recommended partial safety factor $\gamma_M = 1,33$. The recommended partial safety factor γ_M should be used in cases where no value is given in national regulations of the Member State where the fastening screws are used.

The determination of the design values of the pull-out resistance depends on the type of substructure.

For Metal Supporting Substructures the following applies:

The design values of the pull-out resistance are the characteristic values of the pull-out resistance divided by the recommended partial safety factor $\gamma_M = 1,33$. The recommended partial safety factor γ_M should be used in cases where no value is given in national regulations of the Member State where the fastening screws are used.

For Timber Supporting Substructures the following applies:

The design values of the pull-out resistance are the characteristic values of the pull-out resistance multiplied by k_{mod} according to EN 1995-1-1 Section 8.7 (Screwed connections), Table 3.1, and divided by the recommended partial safety factor $\gamma_M = 1,33$. The recommended partial safety factor γ_M should be used in cases where no value is given in national regulations of the Member State where the fastening screws are used.

The design tension resistance $N_{R,d}$ is the minimum value of the design values of either pull-through resistance or relevant pull-out resistance for the corresponding connection.

3. Design Resistance in case of combined Tension and Shear Forces (interaction)

In case of combined tension and shear forces the linear interaction formula according to EN 1993-1-3, section 8.3 (8) should be taken into account.

**SANDWICH PANEL SCREW ESSVE-ST and
SANDWICH PANEL SCREW ESSVE-WD
Fastening screws for sandwich panels**

Determination of Design Values

Annex 7
of European
Technical Assessment
ETA-17/0079